

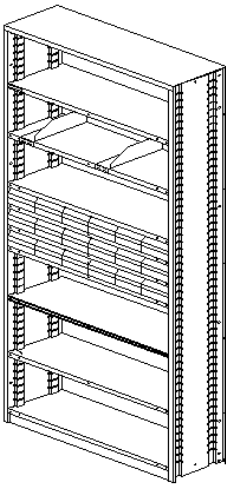

BILT INDUSTRIES, INC.

What you appreciated as Frick-Gallagher® is now BILT. BILT with powder coating.

QUICK-BILT®



KLIP-BILT®

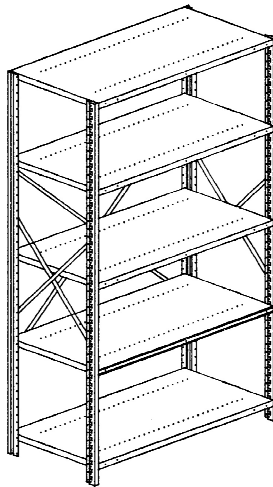

SPEEDI-BILT®

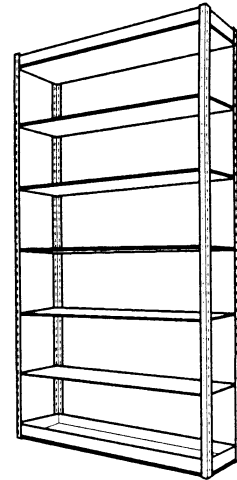

National Sales Office
801 W. Markey Road
Belton, Missouri 64012
Phone: (913) 685-7400
Fax: (913) 685-7996

WEB SITE: www.biltindustries.com
E-MAIL: sales@biltindustries.com

Price Book

Effective March 1, 2009

SPECIFICATIONS KLIP-BILT II® SHELVING

KLIP-BILT II® shelving is industrial duty adjustable steel shelving constructed as a structurally independent unit consisting of posts, shelves, back and side “X” bracing, and/or back and side panels, and required hardware. A variety of accessories can be added to the basic unit to suit particular storage requirements. Standard nominal unit sizes are: 36”, 42”, or 48” wide by 12’, 18”, or 24” deep in heights of 3’-4”, 6’-1”, 7’-1”, or 8’-1”. Other sizes are available.

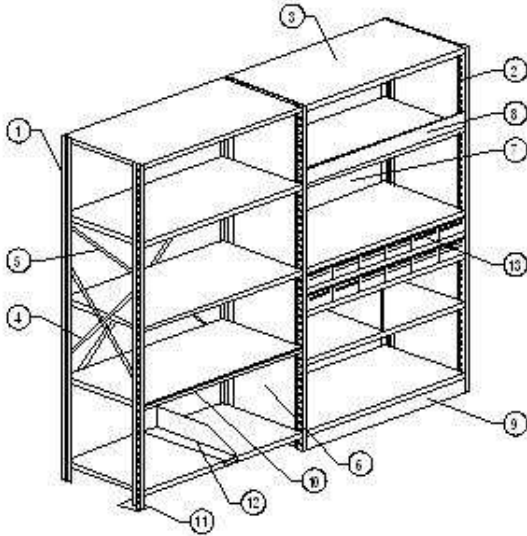

- 1 Angle Post
- 2 Box Post
- 3 Shelf
- 4 Side “X” Brace
- 5 Back “X” Brace
- 6 Side Panel
- 7 Back Panel
- 8 Bin Front
- 9 Base Front
- 10 Label Holder
- 11 Universal Footplate
- 12 Shelf Divider
- 13 Plastic-Bilt Drawer®

Component Parts

OFFSET ANGLE POST – 13 Ga. steel formed into an angle with a 1” front face has a channel shaped offset for added strength. Both flanges is punched with 5/16” holes on 1-1/2” center for attaching sway braces, back/side panels, and certain accessories. The 2-1/16” side flange is punch with 1/2” X 7/16” rectangular slots on 1-1/2” centers to accept shelf clip.

STRONG BOX POST – 13 Ga. steel formed into a tubular shape 3/4” wide X 2-1/16” deep. The 2-1/16” flanges is offset at the back on both sides to form a closed tubular shape and provide added strength. The 3/4” face to be free of punching and be flush with the front flange of the shelf. The 2-1/16” flange is punched with 5/16” holes on 1-1/2” centers for attaching sway braces, side panels, and certain accessories. The 2-1/16” side flanges is also punched with 1/2” X 7/16” rectangular slots on 1-1/2” center to accept shelf clips.

BOX SHELF – 20 Ga. Steel box shelf design is interchangeable with Bilt’s / Frick-Gallagher’s Type A and Type B shelves, plus providing additional capacity form a traditional flange style shelf. The front and back edge is constructed with closed channel that is spot welded with a 5/8” return flange formed at 90°. The corners of the shelf are overlapped, crimped, and notched to accept the standard shelf clip.

SHELF – TYPE A – 18 Ga. steel with all four sides flanged 1-1/8” at 90°. Front and back to have 9/16” return flange. Both sides to have 5/8” return flanges at 90°. Shelf corners to be closed, overlapped, and welded. Front and back flange is punched for attaching reinforcing bars, back panels, and certain accessories. **SHELF – TYPE B** – same as Type A shelf except front and back flanges is reinforced with a flat bar, 11 Ga. X 15/16” wide. Bars may be crimped or bolted in place in the front and back shelf flanges.

KLIP-BILT II® (Industrial Shelving)

OFFSET ANGLE POST 13 Ga.

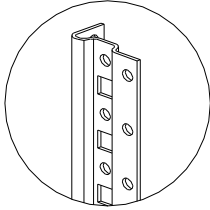

PART #	DESCRIPTION	WT.EA.
40040	OFFSET ANGLE POST 3'-4"	2.8
40021	OFFSET ANGLE POST 6'-1"	5.2
40027	OFFSET ANGLE POST 7'-1"	6.1
40033	OFFSET ANGLE POST 8'-1"	7.0
40045	OFFSET ANGLE POST 10'-1"	8.7
40057	OFFSET ANGLE POST 12'-1"	10.4
40075	OFFSET ANGLE POST 15'-1"	13.0
40099	OFFSET ANGLE POST 20'-1"	17.3

STRONG BOX POST 13 Ga.

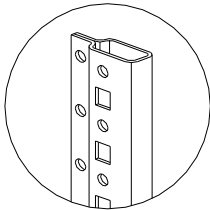

PART #	DESCRIPTION	WT.EA.
40104	STRONG BOX POST 3'-4"	4.3
40121	STRONG BOX POST 6'-1"	7.9
40127	STRONG BOX POST 7'-1"	9.2
40133	STRONG BOX POST 8'-1"	10.4
40145	STRONG BOX POST 10'-1"	13.0
40157	STRONG BOX POST 12'-1"	15.6
40175	STRONG BOX POST 15'-1"	19.5
40199	STRONG BOX POST 20'-1"	25.9

FLAT BACK SWAY BRACE

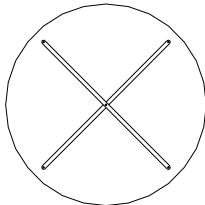

PART #	DESCRIPTION (Sold in pairs)	WT.EA.
44753	FLAT BACK X BRACE-36"	1.1
44754	FLAT BACK X BRACE-42"	1.3
44755	FLAT BACK X BRACE-48"	1.5

BACK PANEL

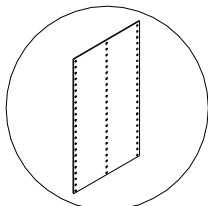

Panels 49" or higher are supplied as (2) or more pieces.

PART #	DESCRIPTION	WT.EA.
40604	BACK PANEL 36 X 3'-4"	9.6
40621	BACK PANEL 36 X 6'-1"	17.5
40627	BACK PANEL 36 X 7'-1"	20.4
40366	BACK PANEL 36 X 8'-1"	23.3
40639	BACK PANEL 36 X 9'-1"	26.2
40645	BACK PANEL 36 X 10'-1"	29.1
40671	BACK PANEL 42 X 6'-1"	20.5
40677	BACK PANEL 42 X 7'-1"	23.9
40683	BACK PANEL 42 X 8'-1"	27.3
40695	BACK PANEL 42 X 10'-1"	34.0
40704	BACK PANEL 48 X 3'-4"	12.8
40721	BACK PANEL 48 X 6'-1"	23.5
40727	BACK PANEL 48 X 7'-1"	27.3
40733	BACK PANEL 48 X 8'-1"	31.2
40745	BACK PANEL 48 X 10'-1"	38.9

PART #	DESCRIPTION	WT.EA.
40370	BOX SHELF – 36" X 12"	7.9
40371	BOX SHELF – 36" X 18"	9.7
40372	BOX SHELF – 36" X 24"	12.4
40380	BOX SHELF – 42" X 24"	14.2
40385	BOX SHELF – 48" X 12"	10.2
40387	BOX SHELF – 48" X 18"	13.0
40388	BOX SHELF – 48" X 24"	16.2

BOX SHELF
20 Ga.

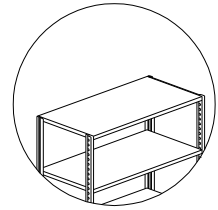

PART #	DESCRIPTION	WT.EA.
43018	BASE FRONT 36 X 2-7/8	1.5
43019	BASE FRONT 42 X 2-7/8	1.7
43020	BASE FRONT 48 X 2-7/8	1.9

BASE FRONT

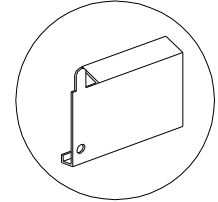

PART #	DESCRIPTION (Sold in pairs)	WT.EA.
43653	SIDE X SWAY BRACE-12"	0.3
43655	SIDE X SWAY BRACE-18"	0.5
43656	SIDE X SWAY BRACE-24"	0.7

SIDE X SWAY

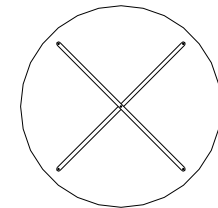

PART #	DESCRIPTION	WT.EA.
43142	BIN FRONT 36 X 3	2.3
43417	BIN FRONT 42 X 3	2.7
43152	BIN FRONT 48 X 3	3.1

BIN FRONT

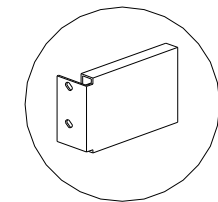

PART #	DESCRIPTION	WT.EA.
41104	SIDE PANEL 12 X 3'-4	2.4
41121	SIDE PANEL 12 X 6'-1	4.5
41127	SIDE PANEL 12 X 7'-1	5.2
41133	SIDE PANEL 12 X 8'-1	6.0
41145	SIDE PANEL 12 X 10'-1	7.4
41204	SIDE PANEL 18 X 3'-4	4.1
41221	SIDE PANEL 18 X 6'-1	7.4
41227	SIDE PANEL 18 X 7'-1	8.7
41233	SIDE PANEL 18 X 8'-1	9.9
41245	SIDE PANEL 18 X 10'-1	12.3
41254	SIDE PANEL 24 X 3'-4	5.7
41271	SIDE PANEL 24 X 6'-1	10.4
41277	SIDE PANEL 24 X 7'-1	12.1
41283	SIDE PANEL 24 X 8'-1	13.8
41295	SIDE PANEL 24 X 10'-1	17.2

SIDE PANEL

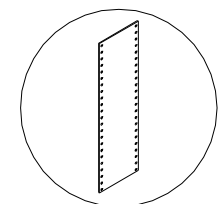

Panels 49" or higher are supplied as (2) or more pieces

SLIDING DIVIDER

PART #	DESCRIPTION	WT.EA.
42254	SLIDING DIVDER 18 X 6	1.6
42256	SLIDING DIVIDER 24 X 6	2.0

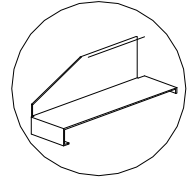

FOOTPLATE

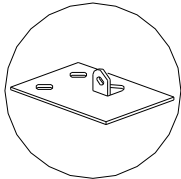

PART #	DESCRIPTION	WT.EA.
45402	FOOTPLATE	.3
45403	SHIM	.3

LICKETY-KLIP®

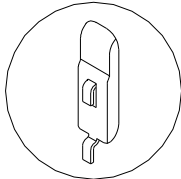

PART #	DESCRIPTION	WT.EA.
46252	LICKETY-KLIP	.1

GUSSET BRACES

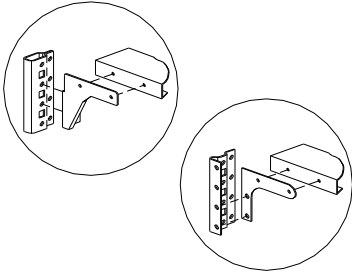

PART #	DESCRIPTION	WT.EA.
44020	OFFSET ANGLE POST	.1
44025	BOX POST (RH)	.3
44026	BOX POST (LH)	.3

SPLICE BRACKETS

PART #	DESCRIPTION	WT.EA.
40100	STRONG BOX POST	.2
40101	ANGLE POST (BACK)	.3
40102	ANGLE POST (SIDE)	.4
40103	ANGLE POST (INTERMEDIATE)	.1

MEZZANINE COMPONENTS

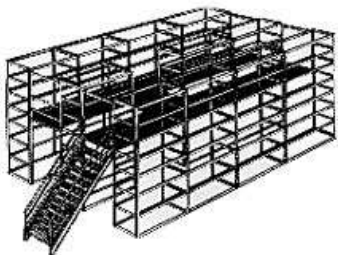

PART #	DESCRIPTION	WT.EA.
27006	FRONT POST BRACKET (RH)	.8
27007	FRONT POST BRACKET (LH)	.8
27012	END AISLE POST BRACKET (RH)	.8
27013	END AISLE POST BRACKET (LH)	.8
27040	CROSS AISLE SUPPORT CHANNEL 36"	5.8
27041	CROSS AISLE SUPPORT CHANNEL 42"	6.8
27042	CROSS AISLE SUPPORT CHANNEL 48"	7.8
27044	END AISLE SUPPORT CHANNEL 36"	5.8
27045	END AISLE SUPPORT CHANNEL 42"	6.8
27046	END AISLE SUPPORT CHANNEL 48"	7.8

QUICK-BILT® (Sliding Shelf Parts Bin)

QUICK-BILT® Shelving is an adjustable sliding shelf unit which is constructed as an open front, structurally independent shell, in which intermediate shelves, dividers, and Plastic-Bilt® Drawers can be inserted and retained without the use of fasteners. Overall nominal unit sizes are: 38" wide X 12" deep in heights of 84" and 96".

PART #	DESCRIPTION	SIZE	WT.EA.
90269	TOP SHELF 18 Ga.	38 x 12	7.5
90272	BASE SHELF 20 Ga.	36 x 12	7.0
90270	INTERMEDIATE SHELF 18 Ga.	36 x 12	6.6
90627	BACK PANEL 24 Ga.	38 x 84	21.5
90629	BACK PANEL 24 Ga.	38 x 96	24.5
91127	END PANEL 20 Ga.	12 x 84	13.4
91129	END PANEL 20 Ga.	12 x 96	15.3
92052	SHELF DIVIDER 22 Ga. (w/ INTEGRAL LABEL HOLDER)	12 x 31/8	.7
90275	MEZZANINE TOP 16 Ga.	38 x 12	6.6
43103	CLEAR PLASTIC LABEL HOLDER	36 x 7/8	.1
216	MAGNETIC RUBBER LABEL HOLDER	3 x 1	.1

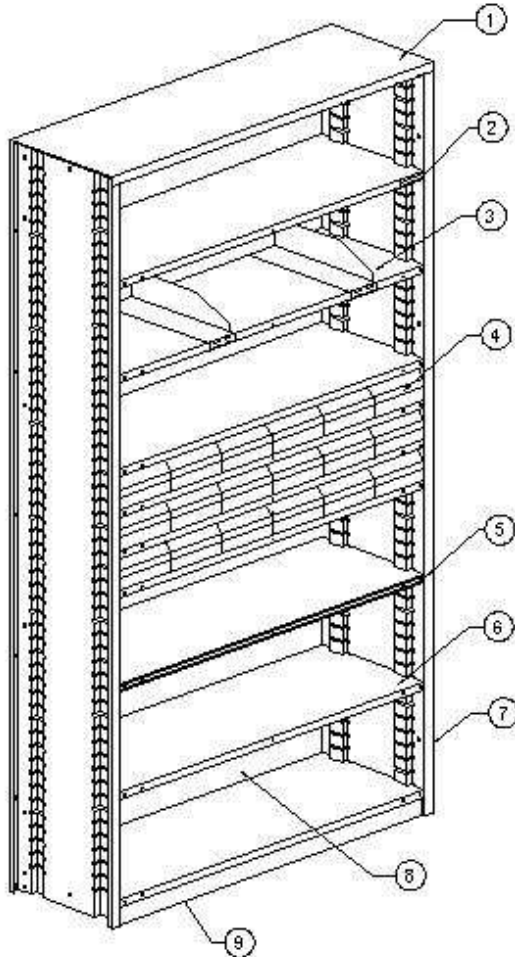

1. Top Shelf
2. 3" Label Holder
3. Sliding Divider
4. Plastic-Bilt Drawer®
5. 36" Label Holder
6. Intermediate Shelf
7. End Panel
8. Back Panel
9. Base Shelf

SPEEDI-BILT® (Rivet Shelving)

ANGLE POST

14 Ga. 1 1/2" X 1 1/2"

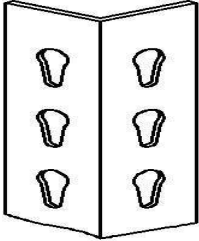

PART #	DESCRIPTION	SIZE	WT.EA.
30004	ANGLE POST	4	2.5
30005	ANGLE POST	5	3.2
30006	ANGLE POST	6	3.8
30007	ANGLE POST	7	4.4
30008	ANGLE POST	8	5
30009	ANGLE POST	9	5.7
30010	ANGLE POST	10	6.3
30011	ANGLE POST	11	7
30012	ANGLE POST	12	7.6

SUPER DUTY ANGLE POST

14 Ga. 1 7/8" X 1 7/8"

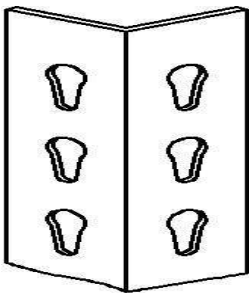

PART #	DESCRIPTION	SIZE	WT.EA.
31004	SB SD ANGLE POST	4	3.4
31005	SB SD ANGLE POST	5	4.3
31006	SB SD ANGLE POST	6	5.2
31007	SB SD ANGLE POST	7	6
31008	SB SD ANGLE POST	8	6.9
31009	SB SD ANGLE POST	9	7.3
31010	SB SD ANGLE POST	10	8.6
31011	SB SD ANGLE POST	11	9.5
31012	SB SD ANGLE POST	12	10.3
31013	SB SD ANGLE POST	13	11.1
31014	SB SD ANGLE POST	14	12
31015	SB SD ANGLE POST	15	12.9
31016	SB SD ANGLE POST	16	13.2

TEE POST

14 Ga.

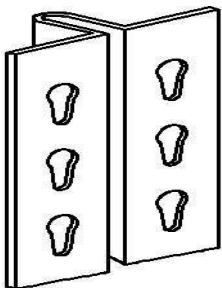

PART #	DESCRIPTION	SIZE	WT.EA.
30204	TEE POST	4	4.9
30205	TEE POST	5	6.1
30206	TEE POST	6	7.3
30207	TEE POST	7	8.6
30208	TEE POST	8	9.8
30209	TEE POST	9	11.1
30210	TEE POST	10	12.5
31211	TEE POST	11	13.9
31212	TEE POST	12	15.3
31213	TEE POST	13	16.7
31214	TEE POST	14	18.1
31215	TEE POST	15	19.5
31216	TEE POST	16	20.2

DOUBLE RIVET

BEAM 14 Ga.

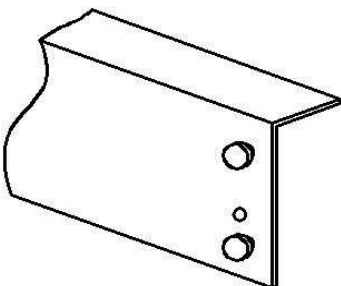

PART #	DESCRIPTION	SIZE	WT.EA.
30112	DBL RIVET BEAM	12	0.9
30115	DBL RIVET BEAM	15	1.2
30118	DBL RIVET BEAM	18	1.4
30124	DBL RIVET BEAM	24	1.9
30130	DBL RIVET BEAM	30	2.3
30132	DBL RIVET BEAM	32	2.5
30136	DBL RIVET BEAM	36	2.8
30142	DBL RIVET BEAM	42	3.2
30148	DBL RIVET BEAM	48	3.7
30154	DBL RIVET BEAM	54	4.2
30160	DBL RIVET BEAM	60	4.7
31560	TIRE BEAM	60	4.7
30169	DBL RIVET BEAM	69	5.4
30172	DBL RIVET BEAM	72	5.6
30184	DBL RIVET BEAM	84	6.5
30196	DBL RIVET BEAM	96	7.5

DOUBLE RIVET CHANNEL 14 Ga.

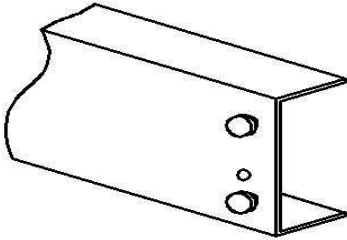

PART #	DESCRIPTION	SIZE	WT.EA.
30360	DBL RIVET CHANL	60	5.7
30369	DBL RIVET CHANL	69	6.8
30372	DBL RIVET CHANL	72	7
30384	DBL RIVET CHANL	84	8.1
30396	DBL RIVET CHANL	96	9.4

SINGLE RIVET BEAM 14 Ga.

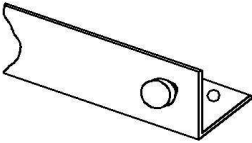

PART #	DESCRIPTION	SIZE	WT.EA.
30212	SGL RIVET BEAM	12	0.5
30218	SGL RIVET BEAM	18	0.7
30224	SGL RIVET BEAM	24	1
30230	SGL RIVET BEAM	30	1.2
30232	SGL RIVET BEAM	32	1.3
30236	SGL RIVET BEAM	36	1.5
30242	SGL RIVET BEAM	42	1.7
30248	SGL RIVET BEAM	48	1.9
30260	SGL RIVET BEAM H.D.	60	4.9

SUPPORT TIE 14 Ga.

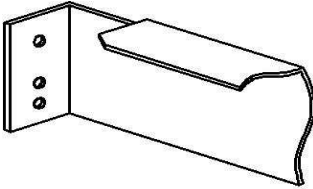

PART #	DESCRIPTION	SIZE	WT.EA.
30412	SUPPORT TIE	12	1.0
30415	SUPPORT TIE	15	1.2
30418	SUPPORT TIE	18	1.5
30424	SUPPORT TIE	24	1.9
30430	SUPPORT TIE	30	2.4
30432	SUPPORT TIE	32	2.6
30436	SUPPORT TIE	36	2.9
30442	SUPPORT TIE	42	3.4
30448	SUPPORT TIE	48	3.8

AISLE SPACER

PART #	DESCRIPTION	SIZE	WT.EA.
31430	AISLE SPACER	30	2.4
31436	AISLE SPACER	36	2.9
31442	AISLE SPACER	42	3.4
31448	AISLE SPACER	48	3.8

ACCESSORIES

PART #	DESCRIPTION	SIZE	WT.EA.
31924	MOBILE HANDLE	24	4
31418	DOUBLE TIE	18	1.5
31409	WALL TIE	9	0.8
30501	TIE PLATES		0.2
30512	FOOTPLATE		0.3

Terms & Conditions

Prices:

All prices are F.O.B. point as quoted. Prices are subject to change without notice and do not include Federal, State, or local taxes.

Terms:

Terms are Net 30 Days - Subject to credit approval.

Shipments:

All transportation charges will be made "collect" unless requested and agreed upon.

Specifications:

The right is reserved to change material, designs or specifications at any time without obligation to subsequent purchases, or to add improvements without making corresponding changes in products previously manufactured.

Special Colors:

Standard color is Gray. Special colors are available; a minimum quantity may be required and is subject to extended shipment date and/or additional cost.

Returns & Cancellations:

No goods are to be returned without factory authorization. All returns must be shipped back in original cartons and packing material, freight prepaid and subject to inspection. A handling charge of 25% will be made for all merchandise returned. Special work and non- stocking items are not subject to cancellation or return.

Damage Shipment:

Customers must inspect each shipment and note any damage or shortages in writing on the freight bill before signing it. Any transit damage claims must be filed with the delivery carrier. If there are concealed damages, shortages, or loss notify the carrier immediately. When you give delivery carrier a clear receipt for a shipment with concealed damages or shortage, the carrier is relieved of further responsibility. Your recourse is with the delivery carrier.

Warranty Provision:

BILT Industries, Inc. warrants all products to be free from defects in material and workmanship for a period of one (1) year of shipment. Products must be used under normal working conditions.